



Vortex Flowmeter

BATTERY POWERED EX DELTA•DIA

MODEL VX Series

GENERAL SPECIFICATION
GS.No.GBD660-3-E

■ GENERAL

With a design to be more usable than ever before, the battery powered EX DELTA and EX DELTA • DIA operate on an internal battery. In this series, the need of an external power source has been eliminated from its big brother, the field proven EX DELTA that has enjoyed extensive use as a dedicated local monitor, thanks to its all-round characteristics of vortex flowmeter.

The display selects variables of the total flow and instantaneous flowrate with an external switch.

We also supply models with separately mountable sensors to be installed across the field - some located as far as 200 meters from the centralized monitor and control room.

■ FEATURES

1. Wide flow range with a high degree of meter accuracy.
2. Liquid service EX DELTA DIA has our proprietary diamond-shaped vortex shedding body combined with a separately-mounted sensor to reduce scale buildup to a minimum, justifying its use with consistent performance in "dirty" process fluid applications (patent applied for).
The sensor being isolated from the process material and a simple design with no moving parts contributes to long service life.
3. Battery powered, it requires no electrical installation from

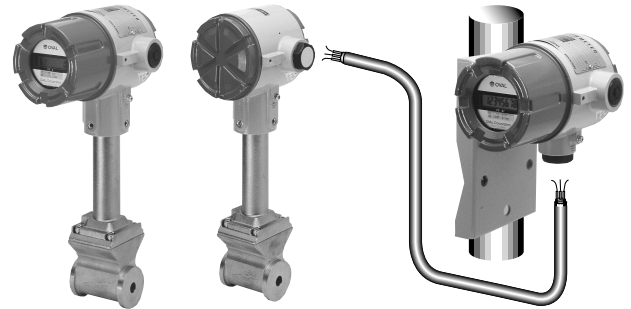

- an external power source. [Uses five 3.6V lithium battery packs. Good for 7 years on a 24 hours a day continuous operation (model integral with preamplifier), or 4 years (model with separately mounted preamplifier) basis.
4. Can monitor the total flow (accumulated total and resettable total) and instantaneous flowrate on the digital display.
5. Waterproof (IP65) and intrinsically safe explosionproof construction (Exia II CT4). Ideal to serve as a flow sensor dedicated to local monitoring.
6. Models with separately mounted preamplifier enables the operator to monitor multiple sensors at a central control room. Max. transmission length is 200 meters.

■ GENERAL SPECIFICATIONS

● EX DELTA Meter Body

Item		Description		
Sensor type		Fixed sensor	Fixed sensor	Replaceable sensor
Nominal size		* 10, 15, 25, 40, 50, 80, 100, 150mm	50, 80, 100, 150, 200, 250, 300mm	50, 80, 100, 150, 200, 250, 300mm
Body style		Wafer type	Flanged type (RF is standard.)	Flanged type (RF is standard.)
Flange rating		JIS 10, 16, 20, 30K ANSI/JPI 150, 300		
Std. connecting pipe		Nominal wall thickness Sch 40		
Applicable fluid		Liquids, gases and steam		
Flow range		See flow range table (P3 and 4).		
Operating temp. range		-30~+300°C Nominal sizes 200~300mm, 0~300°C (Temp. limitation depends on the flange material used.)		Standard type : -30~+300°C High temp. type : -30~+420°C However, min. temp. for nom. size, 200~300mm is specified as 0° due to limitation in material component.
Max. operating pressure		Depends on flange rating (Design pressure : 5.00MPa).		
Accuracy		Select one from the following two ranges according to the given operating conditions: 1: ±1% of indicated reading or better 2: ±1% of full scale or better		
Repeatability		±0.2% or better		
Materials	Body	SCS14A	SUS316 or SCS14A (SUS316 or SFVC2A in nominal sizes 200~300mm)	
	Bluff body (delta or dia. shaped)	SUS316 or SCS14A		
	Adapter	SUS304 or SCS13A		
Installation		No restrictions to cause loss of accuracy on physical orientation Maintainability and waterproof work for cable entry should be taken into consideration.		
Finish (measuring pipe)		Nominal sizes 10~300mm : Remains unfinished (because of stainless steel material) Nominal sizes 200~300mm : Diallyl phthalate resin finished Munsell 7.5G7/2.5 (SFVC2A only)		

* Consult factory in case of gas and steam for nominal size 10mm.

● EX DELTA-DIA Meter Body

Item	Description		
Sensor type	Fixed sensor	Fixed sensor	Replaceable sensor
Nominal size	15, 25, 40, 50, 80mm	50, 80mm	50, 80mm
Body style	Wafer type	Flanged type (RF is standard.)	Flanged type (RF is standard.)
Flange rating	JIS 10, 16, 20, 30K ANSI/JPI 150, 300		
Std. connecting pipe	Nominal wall thickness Sch 40		
Applicable fluid	liquids		
Flow range	See flow range table (P3).		
Materials	Body	SUS316 or SCS14A	
	Bluff body (Diamond shaped)	SUS316 or SCS14A	
	Adapter	SUS304 or SCS13A	
Installation	No restrictions to cause loss of accuracy on physical orientation (Maintainability and waterproof work for cable entry should be taken into consideration.)		
Finish (Measuring Pipe)	Remains unfinished (because of stainless steel material)		

● Flange Rating and Max. Operating Pressure (MPa)

Nominal sizes 10~300mm (with material SUS316 or SCS14A)

Flange Rating / Operating Temp.	JIS10K	JIS16K	JIS20K	JIS30K	ANSI/JPI 150	ANSI/JPI 300
Below 220°C	1.18	1.96	2.45	4.51	1.21	3.20
220~300°C	0.98	1.77	2.26	4.22	1.02	2.91
300~350°C	—	1.57	1.96	3.82	0.84	2.80
350~420°C	—	—	—	2.94	0.56	2.72

Nominal size 200~300mm (with flange material SFVC2A)

Flange Rating / Operating Temp.	JIS10K	JIS16K	JIS20K	JIS30K	ANSI/JPI 150	ANSI/JPI 300
Below 220°C	1.18	2.45	3.04	4.51	1.32	4.31
220~300°C	0.98	2.26	2.84	4.22	1.02	3.87
300~350°C	—	2.06	2.55	3.82	0.84	3.70
350~420°C	—	1.57	1.96	2.94	0.56	2.88

■ CONVERTER SPECIFICATIONS

Item	Description
Model	PA35
Mounting	Select any one of the following types: 1. Compact with meter itself 2. Separated type with 2" pipe stand 1*
Waterproof construction	JIS C 0920 weathertight (IEC IP65)
Explosionproof construction	Intrinsically safe (ExiallCT4)
Operating Temperature	Ambient -20~+60°C
Ambient Humidity	5~100% R.H (without dew condensation)
Accuracy	±1% of RD (or ±1% of FS)
Repeatability	±0.2%
Housing Material	Aluminum alloy
Housing Finish	Finished in baked melamine Finish Munsell 7.5G7/2.5 (Cover: Munsell 10G5/5.5)
Display	LCD : Indication of totalizer, instantaneous flowrate 1: Totalizing Counter, 8 digits 2: Resettable counter, 7 digits 3: Instant. Flowrate (/ h) 4: Instant. Flowrate (/ min) 1, 2, 3, 4 : Select by an external switch. Orientation adjustable for max. readability Low battery alarm with flickering  mark.
Out Put	None
Power Supply	5 lithium battery packs Life: 7 years continuous (for Integral type) 4 years continuous (for separate type)

*1: distance between the meter and converter: Max. 200m.

● Ambient Temperature Range

If the fluid temperature exceeds 125°C, allowable ambient temperature is reduced as shown in the diagram below.

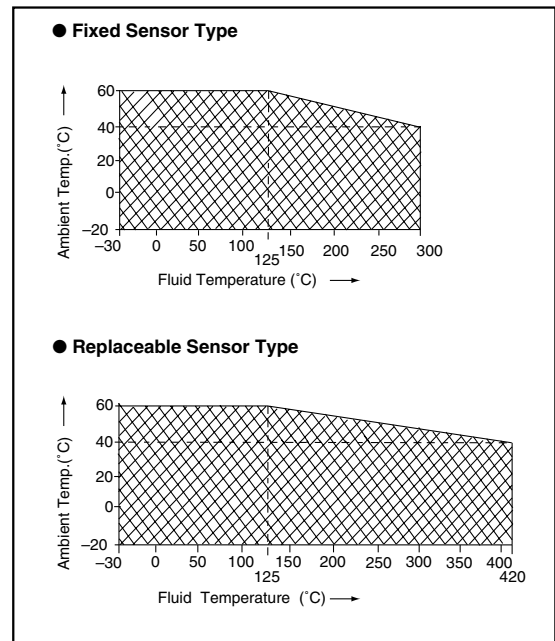

■ VOLUMETRIC UNITS OF TOTALIZING COUNTER

Applicable Fluids	Nom. size mm (inch)	Max. Flowrate m ³ /h	Nom. Meter Factor L/p	Volumetric units Standard	Applicable Fluids	Nom. size mm (inch)	Max. Flowrate m ³ /h	Nom. Meter Factor L/p	Volumetric units Standard
Liquids	10(3/8)	2.8	0.000857	1 L	Gases	15(1/2)	33	0.005338	10 L
	15(1/2)	6.0	0.005338	10 L		25(1)	130	0.01617	100 L
	25(1)	20	0.01617	10 L		40(1 1/2)	290	0.04556	100 L
	40(1 1/2)	48	0.04556	100 L		50(2)	490	0.1001	1 m ³
	50(2)	79	0.1001	100 L		80(3)	1380	0.3328	1 m ³
	80(3)	172	0.3328	100 L		100(4)	2370	0.7567	1 m ³
	100(4)	926	0.7567	100 L		150(6)	5160	2.422	10 m ³
	150(6)	645	2.422	1 m ³		200(8)	9100	7.021	10 m ³
	200(8)	1130	7.021	1 m ³		250(10)	14000	13.54	10 m ³
	250(10)	1750	13.54	1 m ³		300(12)	20100	23.24	10 m ³
300(12)	2510	23.24	1 m ³						

■ MODE SELECT PUSHBUTTON SWITCH

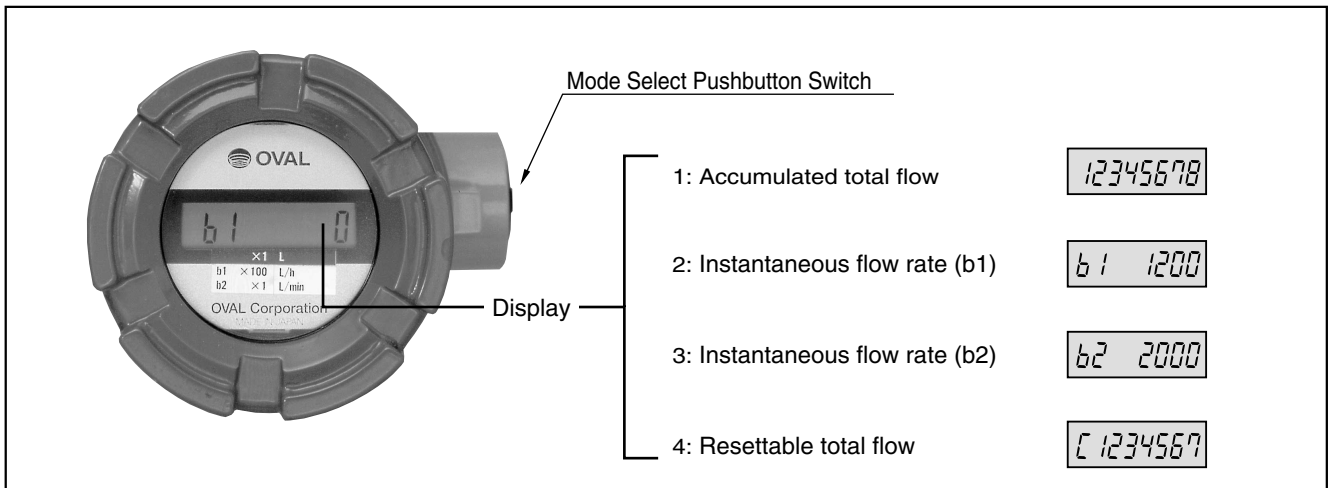

■ EX DELTA•DIA CONSTRUCTION and PRINCIPLE

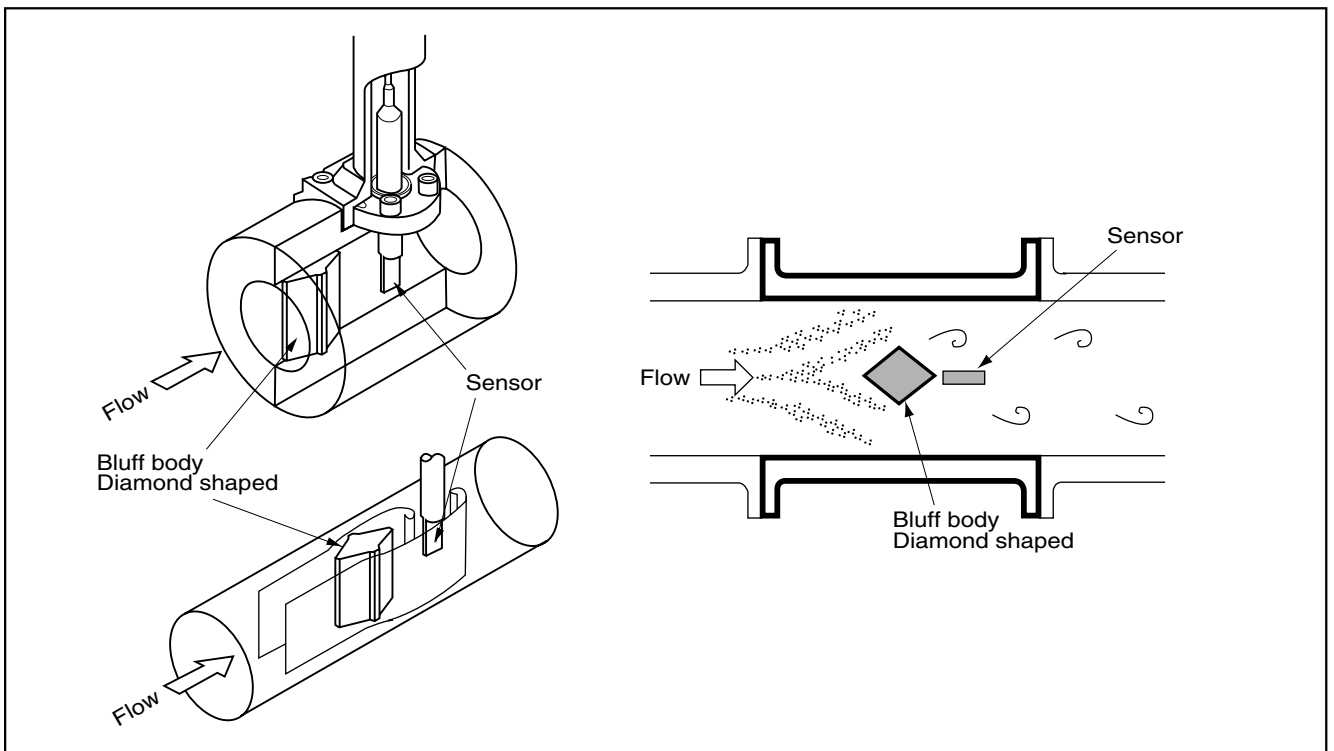

■ FLOW RANGES

● Liquid Service

Select the minimum flow rate from Table A (based on Sp. Gr.) or Table B (based on viscosity), whichever is greater.

Table A (based on specific gravity)

Size mm	Sp. Gr.	Minimum Flowrate							Max. Rate	
		0.5	0.6	0.7	0.8	0.9	1.0	1.1		1.2
10		0.3	0.3	0.3	0.2	0.2	0.2	0.2	0.2	2.8
15		0.4	0.6	0.5	0.5	0.5	0.4	0.4	0.4	6
25		1.0	1.3	1.2	1.1	1.1	1.0	1.0	0.9	20
40		1.7	2.2	2.0	1.9	1.8	1.7	1.6	1.5	48
50		2.7	3.5	3.2	3.0	2.9	2.7	2.6	2.5	79
80		6.0	7.6	7.1	6.6	6.2	5.9	5.7	5.4	172
100		11	11	11	11	11	11	11	11	296
150		33	33	33	33	33	33	33	33	645
200		68	62	57	54	50	48	46	44	1130
250		149	136	126	118	111	106	101	96	1750
300		214	195	181	169	159	151	144	138	2510

Table A (based on specific gravity): EX DELTA·DIA

Unit in m³/h

Nominal size mm (inch)	Sp. Gr.	Minimum Flowrate							Maximum Flowrate	
		0.5	0.6	0.7	0.8	0.9	1.0	1.1		1.2
15 (1/2)		0.6	0.6	0.5	0.5	0.5	0.4	0.4	0.4	6
25 (1)		1.4	1.3	1.2	1.1	1.1	1.0	1.0	0.9	20
40 (1-1/2)		2.4	2.2	2.0	1.9	1.8	1.7	1.6	1.5	48
50 (2)		3.8	3.5	3.2	3.0	2.9	2.7	2.6	2.5	79
80 (3)		8.4	7.6	7.1	6.6	6.2	5.9	5.7	5.4	172

Table B (based on viscosity)

Unit in m³/h

Size mm	Accuracy	K. Viscosity	Minimum Flowrate										
			1	2	3	5	10	15	20	25	30	40	
10	±2%FS			0.3	0.4	0.6	1.1	1.7	Beyond Measurement				
15	±1%RD		0.8	1.6	2.4	3.9	Beyond Measurement						
	±1%FS		0.4	1.2	1.8	2.9					Beyond Measurement		
25	±1%RD		1.6	3.1	4.6	7.6	16	Beyond Measurement					
	±1%FS					1.8	5.9					11	15
40	±1%RD		2.4	4.7	7.0	12	24	35	Beyond Measurement				
	±1%FS					2.8	6.5	14				22	29
50	±1%RD		3.0	6.0	9.0	15	30	45	60	Beyond Measurement			
	±1%FS					3.6	7.1	15	24			34	42
80	±1%RD			8.9	14	23	45	67	89	110	130		
	±1%FS					11	16	26	38	53	82		
100	±1%RD			12	18	29	58	87	120	150	180	230	
	±1%FS					14	21	28	45	55	96		
150	±1%RD					43	86	130	170	220	260	340	
	±1%FS								41	51	61	100	
200	±1%RD							113	170	230	280	340	450
	±1%FS									68	81	110	
250	±1%RD						140	210	280	350	420	560	
	±1%FS										140		
300	±1%RD					170	250	340	420	500	680		
	±1%FS								180	230			

● In the shadowed area [], determine on the basis of specific gravity (Table A).

● RD : Reading, FS : Full Scale

● Gas Service

In this table, flow rates are specified in [actual] base. Therefore, in case of [normal] base, make it sure to convert the flow rate to [actual] conditions and determine the flow range and the nominal diameter based on this table.

Size mm	Accuracy	Dens.kg/m ³	Minimum Flowrate (m ³ /h)										Max. Flowrate (m ³ /h)
			0.38	0.7	1.2	2.0	3.6	6	11	19	34	(60)	
Table "C"	15	±1% of Reading	—	—	12	7.2	4.0	3.2	2.6	2.2	1.8	1.5	33
		±1% of Full scale	9.4 [⊙]	6.9 [⊙]	5.4 [⊙]	4.6	3.8	3.2	2.6	2.2	1.8	1.5	
	25	±1% of Reading	68	37	22	13	10	8	7	6	5	4	130
		±1% of Full scale	23	17	13	12	10	8	7	6	5	4	
	40	±1% of Reading	110	57	33	20	16	13	11	9	8	6	290
		±1% of Full scale	39	29	23	19	16	13	11	9	8	6	
	50	±1% of Reading	110	73	43	31	26	22	18	15	12	10	490
		±1% of Full scale	63	46	37	31	26	22	18	15	12	10	
	80	±1% of Reading	200	108	80	67	56	47	38	32	26	22	110(1380)
		±1% of Full scale	140	101	80	67	56	47	38	32	26	22	
	100	±1% of Reading	260	174	140	115	95	80	66	55	45	37	1850(2370)
		±1% of Full scale	240	174	140	115	95	80	66	55	45	37	
	150	±1% of Reading	520	380	300	260	210	180	150	120	110	110	4180(5160)
	200	±1% of Reading	900	670	520	440	370	310	250	250	250	250	7000(9100)
	250	±1% of Reading	2000	1470	1120	980	800	680	560	490	490	490	10500(14000)
	300	±1% of Reading	2900	2100	1600	1400	1150	970	840	840	840	840	15000(20100)
Table "D"	Kind of Gas	Dens. kg/Nm ³	Gas pressure(MPa [gauge])at 20°C										Gas viscosity
	Acetylene	1.175	—	—	0	0.08	0.23	0.55	0.9	1.65	3	—	0.00943(mPa·s)
	Argon	1.785	—	—	—	0.02	0.12	0.26	0.55	1.05	2	3.6	0.007
	Ammonia	0.771	—	0	0.07	0.21	0.42	0.75	1.45	2.55	4.6	—	0.0092
	Carbon Monoxide	1.250	—	—	0	0.07	0.21	0.42	0.85	1.55	2.8	—	0.0166
	Ethane	1.357	—	—	0	0.06	0.18	0.37	0.8	1.4	2.6	—	0.0085
	Ethylene	1.264	—	—	0	0.07	0.21	0.42	0.85	1.55	2.8	—	0.0097
	Air	1.293	—	—	0	0.07	0.20	0.4	0.85	1.5	2.7	—	0.017
	Oxygen	1.429	—	—	0	0.05	0.17	0.35	0.75	1.35	2.5	4.4	0.0192
	Hydrogen	0.0899	0.35	0.73	1.33	2.3	4.2	—	—	—	—	—	0.0084
	Carbon Dioxide	1.977	—	—	—	0.01	0.1	0.23	0.5	0.95	1.7	3.3	0.0138
	Nitrogen	1.251	—	—	—	0.07	0.21	0.42	0.85	1.55	2.8	—	0.0166
	City Gas	0.802	—	0	0.06	0.17	0.38	0.7	1.4	2.45	4.5	—	0.01
	Natural Gas	0.828	—	0	0.06	0.16	0.37	0.68	1.35	2.4	4.3	—	0.0107
	Freon-12	5.533	—	—	—	—	0	0.02	0.12	0.27	0.56	1.1	0.0127
	Propane	2.020	—	—	—	0.01	0.09	0.22	0.49	0.9	1.7	3.2	0.0075
Butane	2.703	—	—	—	0	0.04	0.14	0.34	0.65	1.2	2.4	0.0069	
Methane	0.717	—	0	0.08	0.2	0.44	0.8	1.55	2.8	—	—	0.0103	

Note: In nominal size 15mm, figures marked ⊙ indicate ±2% of full scale. Figures in brackets () in the max. rate indicate with ±1.5% of readings.

How to Determine the Minimum Flowrate

Find a value nearest (lower side) to the applicable gas pressure in Table D, follow the same column upwards and find a value intersecting the desired nominal size in Table C for the minimum flowrate. If it is desired to determine the minimum flowrate more accurately, calculate it as follows:

EXAMPLE 1

Find the minimum flowrate where: Fluid:Air, Temperature:20°C, Pressure:0.5MPa (gauge) and nominal size: 80mm.

SOLUTION:Minimum flowrate at 0.4MPa and 0.85MPa of air with respect to nominal diameter 80mm in Table D are 47m³/h and 38m³/h, respectively, from Table C. The minimum flow rate at 0.5MPa is therefore determined by proportion as follows:

$$Q_{\min} = 38 + \frac{0.85 - 0.5}{0.85 - 0.4} \times (47 - 38) \doteq 45 \text{ m}^3/\text{h}$$

It can also be determined by calculating the actual density. Actual density of air ρ at 20°C at 0.5MPa is

$$\rho = 1.293 \times \frac{273.15}{273.15 + 20} \times \frac{0.1013 + 0.5}{0.1013} \doteq 7.04 \text{ kg/m}^3$$

From Table C, the minimum flowrate at a density of 6 and nominal size 80mm is 47m³/h; at a density of 11 is 38m³/h. The minimum flowrate at a density of 7.04 therefore can be found by proportion as follow:

$$Q_{\min} = 38 + \frac{11 - 7.04}{11 - 6} \times (47 - 38) \doteq 45 \text{ m}^3/\text{h}$$

EXAMPLE 2

Find the minimum flowrate and applicable nominal size where: Fluid: Carbon dioxide, Temperature:5~30°C, Pressure 0.8~1.5MPa, Max. flowrate:1800m³/h (normal).

SOLUTION:First, we find the actual max. flowrate and determine the nominal diameter. If there is some latitude in temperature and pressure, the maximum flowrate should be calculated on the basis of the high end in temperature and in pressure. The actual maximum flow rate is therefore computed as follows:

$$Q_{\text{Max.}} = 1800 \times \frac{273.15 + 30}{273.15} \times \frac{0.1013}{0.1013 + 0.8} \doteq 228 \text{ m}^3/\text{h}$$

It follows that the nominal size is 40mm and the minimum flowrate is based on the low end in temperature and in pressure.

From Tables D and C, the minimum flowrate at 40mm size and 0.95MPa pressure is 9m³/h, at 1.7MPa, it is 8m³/h. We then obtain the minimum flowrate by proportional way as

$$Q_{\min} = 8 + \frac{1.7 - 1.5}{1.7 - 0.95} \times (9 - 8) \doteq 8.3 \text{ m}^3/\text{h}$$

NOTE:In cases where obtained results of calculation are figures with decimal places, omit fractions below the decimal point in the maximum flowrate, or count fractions as a whole number in the minimum flowrate.

● **Saturated Steam Service**

(Accuracy : Better than ± 1% of reading) Unit in kg/h (Nom. sizes 15~40mm) t/h (Nom. sizes 50~300mm)

Pressure MPa(gauge)	15mm(1/2")		125mm(1")		40mm(1 1/2")		50mm(2")		80mm(3")		100mm(4")		150mm(6")		200mm(8")		250mm(10")		300mm(12")	
	Min.	Max.	Min.	Max.	Min.	Max.	Min.	Max.	Min.	Max.	Min.	Max.	Min.	Max.	Min.	Max.	Min.	Max.	Min.	Max.
0.049	Δ 5.5 10	29	14	112	Δ 22 29	250	0.04	0.42	0.08	0.95 (1.19)	0.14	1.60 (2.04)	0.30	3.61 (4.46)	0.52	6.05 (7.82)	1.14	9.09 (12.1)	1.64	12.9 (17.3)
0.098	Δ 6 10	37	20	146	Δ 25 29	326	0.05	0.55	0.09	1.23 (1.55)	0.16	2.08 (2.66)	0.34	4.70 (5.80)	0.59	7.89 (10.1)	1.31	11.8 (15.7)	1.87	16.8 (22.6)
0.196	Δ 8 10	54	21	212	33	475	0.06	0.80	0.12	1.80 (2.25)	0.21	3.03 (3.87)	0.44	6.84 (8.44)	0.77	11.4 (14.8)	1.71	17.1 (22.9)	2.45	24.5 (32.8)
0.294	10	71	24	278	39	620	0.07	1.04	0.15	2.35 (2.95)	0.25	3.95 (5.06)	0.53	8.94 (11.0)	0.92	14.9 (19.3)	2.04	22.4 (29.9)	2.92	32.0 (42.9)
0.392	11	87	27	342	45	764	0.08	1.29	0.17	2.89 (3.63)	0.28	4.87 (6.23)	0.61	11.0 (13.5)	1.06	18.4 (23.8)	2.34	27.6 (36.8)	3.36	39.5 (52.8)
0.490	13	103	30	406	51	906	0.09	1.53	0.19	3.43 (4.31)	0.32	5.78 (7.40)	0.68	13.0 (16.1)	1.19	21.8 (28.2)	2.63	32.8 (43.7)	3.76	46.9 (62.7)
0.588	14	119	34	469	56	1040	0.10	1.77	0.20	3.97 (4.98)	0.35	6.68 (8.55)	0.75	15.1 (18.6)	1.31	25.3 (32.6)	2.89	37.9 (50.6)	4.14	54.2 (72.5)
0.686	15	135	37	532	61	1180	0.10	2.00	0.22	4.50 (5.65)	0.38	7.58 (9.70)	0.81	17.1 (21.1)	1.42	28.6 (37.0)	3.14	43.0 (57.3)	4.50	61.4 (82.2)
0.785	16	151	39	595	65	1320	0.11	2.24	0.24	5.03 (6.32)	0.40	8.47 (10.8)	0.88	19.1 (23.6)	1.53	32.0 (41.4)	3.38	48.1 (64.1)	4.85	68.7 (91.9)
0.883	17	167	42	658	70	1460	0.12	2.48	0.25	5.57 (6.98)	0.43	9.36 (11.9)	0.94	21.1 (26.1)	1.64	35.4 (45.7)	3.62	53.1 (70.9)	5.18	75.9 (101)
0.981	18	183	45	721	74	1610	0.13	2.72	0.27	6.10 (7.66)	0.46	10.3 (13.1)	1.00	23.2 (28.6)	1.74	38.8 (50.1)	3.85	58.3 (77.7)	5.51	83.2 (111)
1.08	19	199	47	784	78	1740	0.13	2.95	0.28	6.63 (8.32)	0.49	11.1 (14.2)	1.05	25.2 (31.1)	1.84	42.2 (54.5)	4.07	63.3 (84.4)	5.83	90.4 (121)
1.18	20	215	50	846	82	1880	0.14	3.18	0.30	7.15 (8.98)	0.51	12.0 (15.4)	1.11	27.2 (33.5)	1.93	45.5 (58.8)	4.28	68.3 (91.1)	6.13	97.6 (130)
1.27	21	230	52	907	86	2020	0.15	3.42	0.31	7.67 (9.63)	0.53	12.9 (16.5)	1.16	29.1 (35.9)	2.03	48.8 (63.0)	4.48	73.2 (97.7)	6.42	104 (140)
1.37	22	246	54	969	90	2160	0.15	3.65	0.33	8.20 (10.2)	0.56	13.7 (17.6)	1.21	31.1 (38.4)	2.12	52.1 (67.3)	4.68	78.3 (104)	6.71	111 (149)
1.47	23	262	57	1030	94	2300	0.16	3.88	0.34	8.72 (10.9)	0.58	14.6 (18.7)	1.26	33.1 (40.9)	2.21	55.5 (71.7)	4.88	83.3 (111)	6.99	119 (159)
1.57	24	278	59	1090	98	2440	0.16	4.12	0.35	9.26 (11.6)	0.60	15.5 (19.9)	1.31	35.1 (43.4)	2.30	58.9 (76.0)	5.08	83.3 (117)	7.27	126 (168)
1.67	25	294	61	1150	101	2580	0.17	4.35	0.37	9.78 (12.2)	0.63	16.4 (21.0)	1.36	37.1 (45.8)	2.38	62.2 (80.4)	5.27	93.4 (124)	7.55	133 (178)
1.77	26	310	63	1220	105	2720	0.18	4.60	0.38	10.3 (12.9)	0.65	17.3 (22.2)	1.41	39.2 (48.4)	2.47	65.7 (84.8)	5.46	98.5 (131)	7.86	140 (188)
1.86	27	326	66	1280	109	2860	0.18	4.83	0.39	10.8 (13.6)	0.67	18.2 (23.3)	1.46	41.2 (50.8)	2.55	69.0 (89.1)	5.64	103 (138)	8.26	148 (198)
1.96	27	342	68	1340	112	3000	0.19	5.07	0.41	11.3 (14.2)	0.69	19.1 (24.5)	1.50	43.2 (53.3)	2.63	72.4 (93.5)	5.82	108 (144)	8.66	155 (207)
2.94	35	502	87	1970	145	4410	0.24	7.45	0.52	16.7 (20.9)	0.90	28.1 (36.0)	1.94	63.5 (78.4)	3.85	106 (137)	7.53	159 (212)	12.8	228 (305)
3.92	43	667	106	2620	175	5860	0.29	9.90	0.63	22.2 (27.8)	1.08	37.3 (47.8)	2.35	84.4 (104)	5.11	141 (182)	9.86	212 (282)	17.0	303 (405)
4.22	45	717	111	2820	184	6300	0.30	10.6	0.66	23.9 (29.9)	1.13	40.2 (51.4)	2.46	90.8 (112)	5.50	152 (196)	10.6	228 (304)	18.2	326 (436)

Δ : Accuracy: ± 1% of full scale (): Accuracy: ± 1.5% of reading

● **Superheated Steam Service**

The superheated steam flow range is determined by first finding the correction factors "a" and "b" for the min. rate and max. rate, respectively, from the curves below and then

multiplying the applicable nominal size and pressure readings in the saturated steam flow range table by these correction factors.

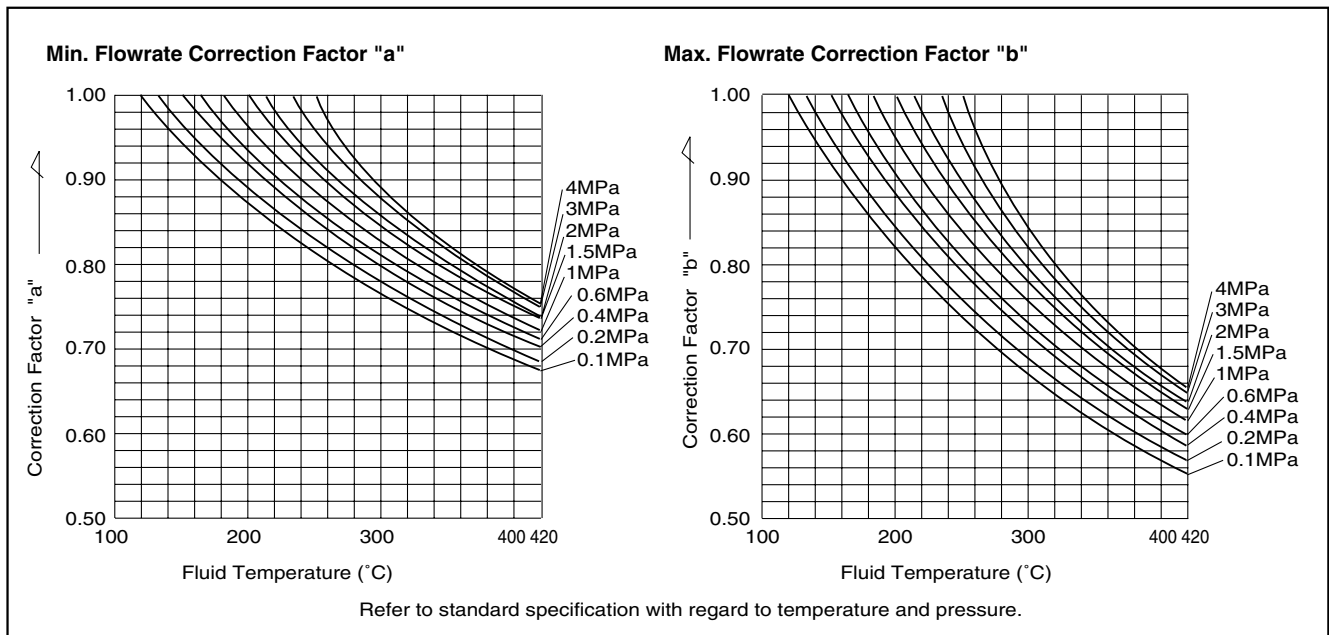

EXAMPLE : Find the flow range of superheated steam where Nominal size : 50mm, Pressure : 1MPa (gauge) and Temperature 250°C.

SOLUTION : From the curves, correction factors are : a= 0.890, b= 0.840. So we obtain

Min. flowrate $Q_{min} = 0.890 \times 130 = 115.7 \text{ kg/h}$
 Max. flowrate $Q_{max} = 0.840 \times 2720 = 2285 \text{ kg/h}$

IMPORTANT: 1. In applications where flowrate momentarily exceeds the max. rate, hold that peak value within 1.6 times the max. rating.

2. In a ±1% of full scale specification, if the flow range is $\frac{\text{Full scale flowrate}}{\text{Min. flowrate}} < 4$, then a ± 2% of full scale is applied.

■ PRESSURE LOSSES

● Nominal Sizes 10~150mm

* 10mm : Liquid only

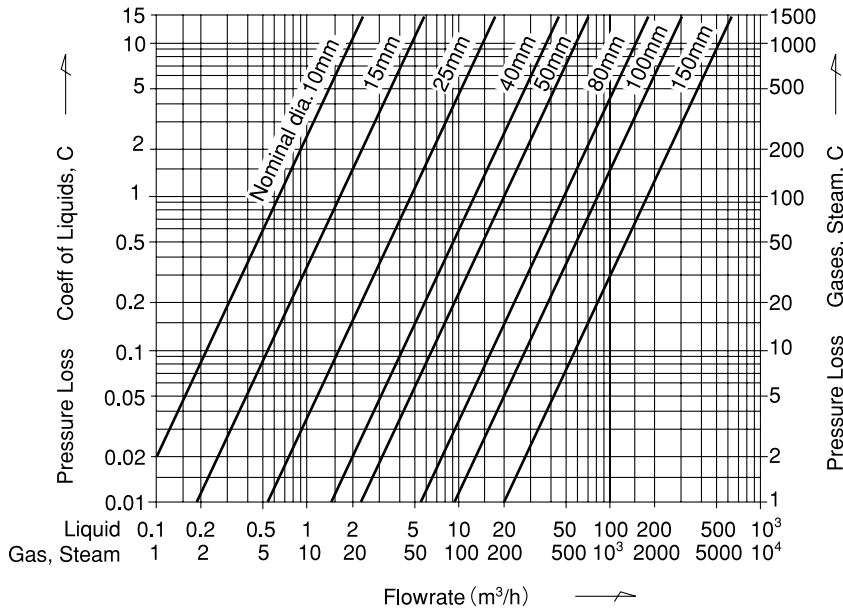

$$\Delta P = \frac{C \times \rho}{100}$$

ΔP : Pressure loss (kPa)

ρ : Density (kg/m³)

To determine the pressure loss, find the value C at the intersecting point of flow rate (Q) and slanted line of the given meter diameter and substitute it to the formula above.

● Nominal Sizes 200, 250, 300mm

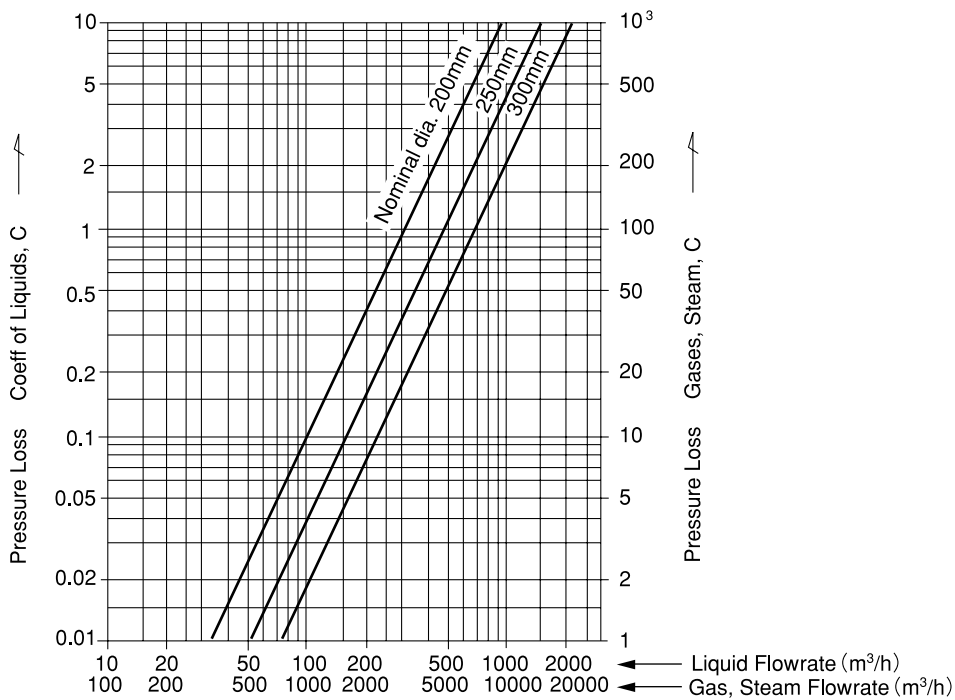

■ SCALED PULSE UNITS FOR FIXED CONVERSION

When it is required that a volume flowrate (flowrate in terms of volume) be reduced to the equivalent flowrate under standard conditions (normal flowrate) or to the mass flowrate in a fixed conversion by multiplying a conversion factor, the scaled pulse unit is determined by the unit selector graphs given below.

● Case 1

1. "Conversion factor" is calculated by the following equation:

$$\text{Conversion factor} = \frac{273.15}{T+273.15} \times \frac{P+0.1013}{0.1013} \times \frac{Z_0}{Z}$$

(Except where significant influence is anticipated, it is assumed that $Z_0/Z=1$.)

where T=Operating temp.(°C)

P=Operating press.(MPa[gaug])

Z_0 =Compressibility coefficient under standard conditions.

Case	Fluid Type	Type of Conversion	Reference
1	Gases	Conversion into standard conditions (normal flowrate)	Tables A, B
2	Saturated steam	Conversion into mass flowrate	Tables C, D
3	Gases, super-heated steam	Conversion into mass flowrate	Tables E, F
4	Liquids	Conversion into mass flowrate	Tables G, H

Z =Compressibility coefficient under operating conditions.

- Follow your way to the right in the nominal bore size column of the given meter in Table A and find the segment number (①,②,etc.) that agrees with the conversion factor you have just computed. Example: Nom. size 50mm, $0.735 \leq ④ < 0.776$
- In Table B, find the scaled pulse unit relative to the segment number.

Table A ● Conversion Factor — Segment Graph

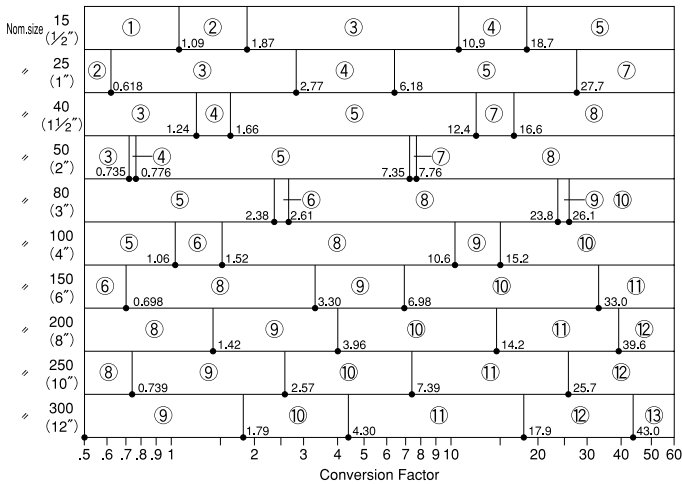

Table B ● Segment — Scaled Pulse Output

Segment No.	Scaled pulse output units : [normal]		
	Minimum	Standard	Maximum
①	1 L/P	10 L/P	100 L/P
②	10 L/P	100 L/P	100 L/P
③			1 m³/P
④	100 L/P	1 m³/P	1 m³/P
⑤			10 m³/P
⑥			100 m³/P
⑦	1 m³/P	10 m³/P	10 m³/P
⑧			100 m³/P
⑨			1000 m³/P
⑩			1000 m³/P
⑪	10 m³/P	100 m³/P	10000 m³/P
⑫			10000 m³/P
⑬	100 m³/P	1000 m³/P	100000 m³/P

● Case 2

1. Follow your way to the right in the nominal size column of the given meter in Table C and find the segment number (①,②,etc.) that agrees with the saturated steam pressure.

2. In Table D, find the scaled pulse unit relative to the segment number.

Table C ● Pressure (Gase Pressure)— Segment Graph

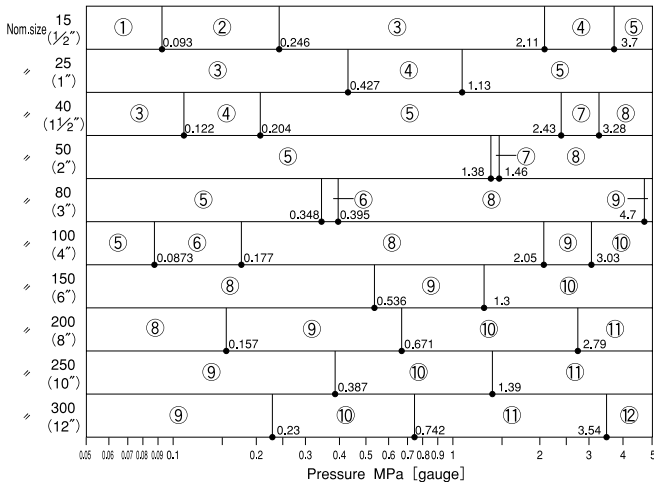

Table D ● Segment — Scaled Pulse Output

Segment No.	Scaled pulse output units : [normal]		
	Minimum	Standard	Maximum
①	1 g/P	10 g/P	100 g/P
②	10 g/P	100 g/P	100 g/P
③			1 kg/P
④	100 g/P	1 kg/P	1 kg/P
⑤			10 kg/P
⑥			100 kg/P
⑦	1 kg/P	10 kg/P	10 kg/P
⑧			100 kg/P
⑨			1 t/P
⑩			1 t/p
⑪	10 kg/P	100 kg/P	10 t/P
⑫			100 kg/P

● **Case 3**

1. Follow your way to the right in the nominal size column of the given meter in Table E and find the segment Number (①, ②, etc.) that agrees with the density when in use.

2. In Table E, find the scaled pulse unit relative to the segment number.

Table E ● Density — Segment Graph

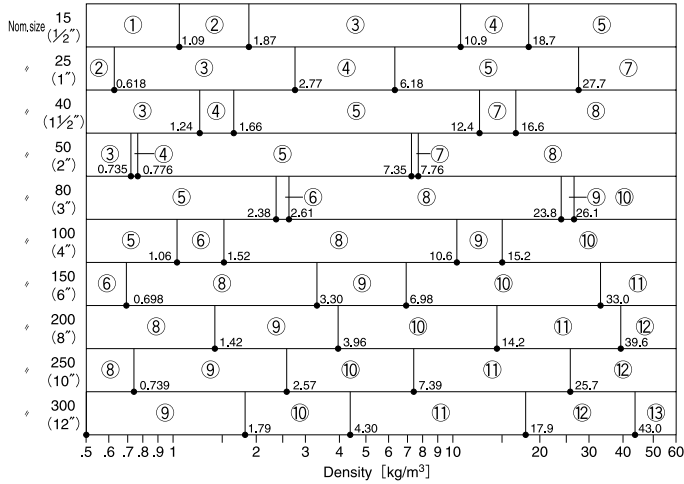

Table F ● Segment — Scaled Pulse Output

Segment No.	Scaled pulse output units : [normal]		
	Minimum	Standard	Maximum
①	1 g/P	10 g/P	100 g/P
②	10 g/P	100 g/P	100 g/P
③			1 kg/P
④	100 g/P	1 kg/P	1 kg/P
⑤			10 kg/P
⑥			100 kg/P
⑦	1 kg/P	10 kg/P	10 kg/P
⑧			100 kg/P
⑨	10 kg/P	100 kg/P	1 t/P
⑩			1 t/P
⑪			10 t/P
⑫	100 kg/P	1 t/P	10 t/P
⑬			100 t/P

● **Case 4**

1. Follow your way to the right in the nominal size column of the given meter in Table G and find the segment Number (①, ②, etc.) that agrees with the density when in use.

2. In Table H, find the scaled pulse unit relative to the segment number.

Table G ● Specific Gravity — Segment Graph

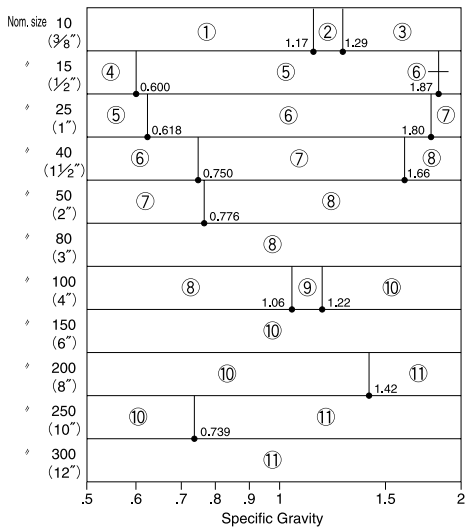

Table H ● Segment — Scaled Pulse Output

Segment No.	Scaled pulse output units: [normal]		
	Minimum	Standard	Maximum
①	10 g/P	1 kg/P	10 kg/P
②	100 g/P	1 kg/P	100 kg/P
③	100 g/P	10 kg/P	100 kg/P
④	100 g/P	1 kg/P	10 kg/P
⑤	1 kg/P	10 kg/P	100 kg/P
⑥	1 kg/P	10 kg/P	1 t/P
⑦	10 kg/P	100 kg/P	1 t/P
⑧	10 kg/P	100 kg/P	10 t/P
⑨	100 kg/P	1 t/P	10 t/P
⑩	100 kg/P	1 t/P	100 t/P
⑪	1 t/P	10 t/P	1000 t/P

EX DELTA OUTLINE DIMENSIONS [INTEGRAL TYPE] (Unit in mm)

Wafer Type

- Nominal Sizes 10, 15, 25mm

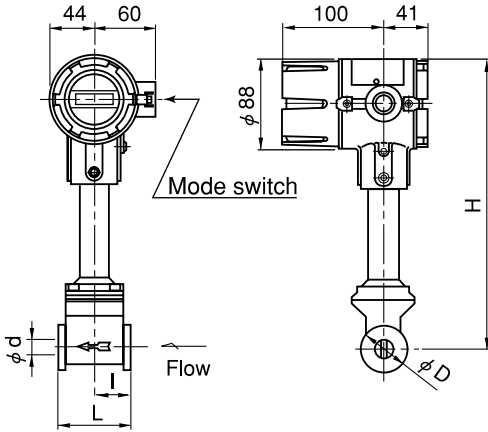

- Nominal Sizes 40~150mm

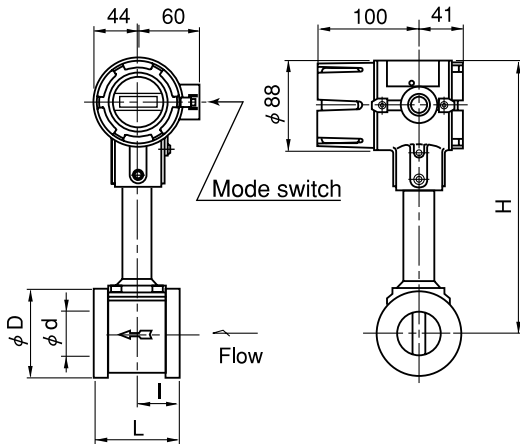

Nominal Size mm (inch)	L	I	φd (Meter I.D.)	φD	H	Approx. Mass (kg)
10 (3/8")	65	32.5	10	40	277	2.6
15 (1/2")	65	32.5	14.5	40	277	2.6
25 (1")	65	32.5	26.6	67	277	3.2
40 (1 1/2")	80	40	37.6	81	262	3.9
50 (2")	80	40	48.5	91	266	4.0
80 (3")	100	40	72.4	126	282	6.8
100 (4")	125	48	95.2	156.2	302	10.5
150 (6")	165	54	140.3	214.9	332	20.4

Flanged Type

- Fixed Sensor Type
- Nominal Sizes 50~150mm

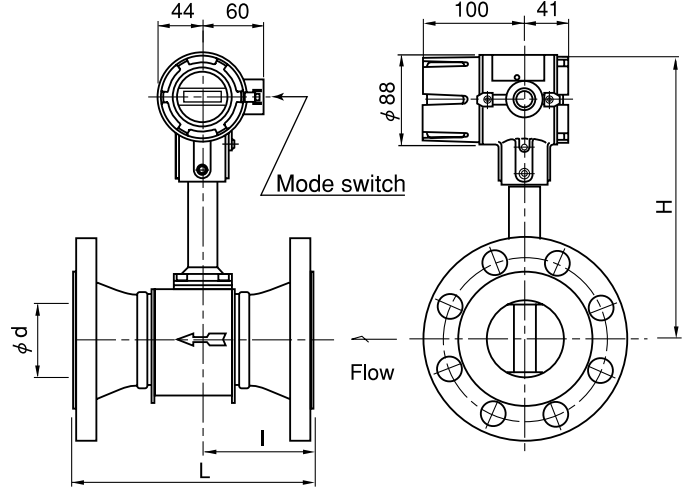

- Nominal Sizes 200~300mm

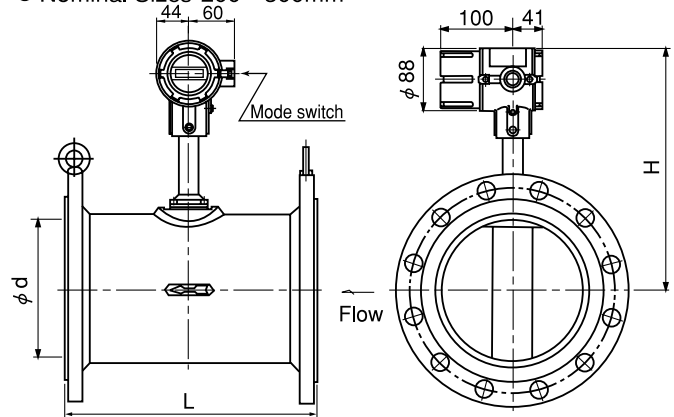

Nominal Size mm (inch)	Frange Rating	L	I	φd (Meter I.D.)	H	Approx. Mass (kg)
50 (2")	JIS10K	173	86.5	48.5	266	9.0
	JIS20K (16K)	181	90.5			9.2
	JIS30K	191	95.5			11.3
	ANSI150	204	102			9.9
	JPI150					10.0
	ANSI300	217	108.5			11.8
80 (3")	JIS10K	219	99.5	72.4	282	15.2
	JIS20K (16K)	233	106.5			17.9
	JIS30K	243	111.5			21.9
	ANSI150	237	108.5			18.0
	JPI150					
	ANSI300	255	117.5			22.5
100 (4")	JIS10K	250	110.5	95.2	302	21.2
	JIS20K (16K)	264	117.5			25.2
	JIS30K	274	122.5			31.8
	ANSI150	274	122.5			26.5
	JPI150					26.6
	ANSI300	294	132.5			36.0
150 (6")	JIS10K	322	132.5	140.3	332	43.7
	JIS20K (16K)	342	142.5			52.8
	JIS30K	352	147.5			66.4
	ANSI150	340	141.5			46.5
	JPI150					46.6
	ANSI300	359	151			65.6
200 (8")	—	350	—	199.9	347	38.3
250 (10")	—	450	—	248.8	369	68.8
300 (12")	—	500	—	297.9	391	88.8

- Replaceable Sensor Type
- Nominal Sizes 50~150mm

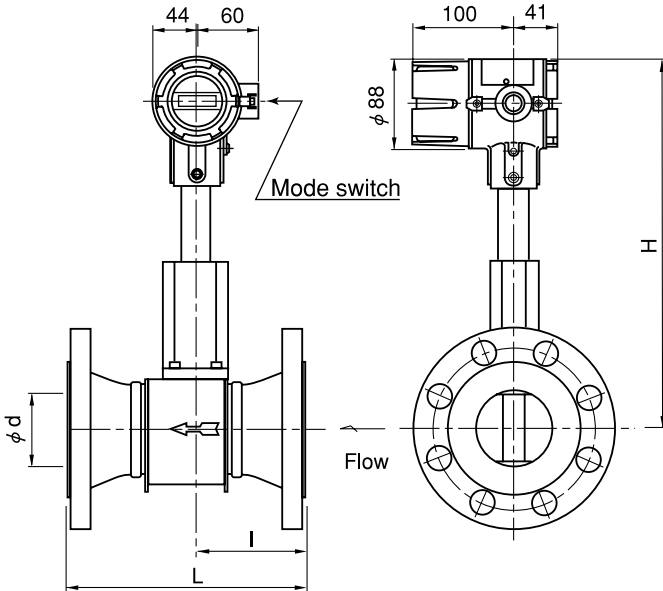

- Nominal Sizes 200~300mm

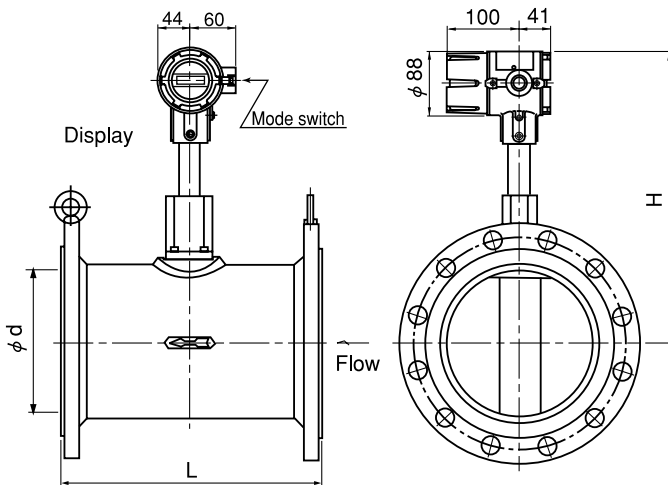

Nominal Size mm (inch)	Frang Rating	L	I	ϕd (Meter I.D.)	H	Approx. Mass (kg)
50 (2")	JIS10K	173	86.5	48.5	347	9.6
	JIS20K (16K)	181	90.5			9.8
	JIS30K	191	95.5			11.9
	ANSI150	204	102			10.5
	JPI150					10.6
	ANSI300	217	108.5			12.4
80 (3")	JIS10K	219	99.5	72.4	363	15.8
	JIS20K (16K)	233	106.5			18.5
	JIS30K	243	111.5			22.5
	ANSI150	237	108.5			18.6
	JPI150					
	ANSI300	255	117.5			23.1
100 (4")	JIS10K	250	110.5	95.2	383	21.8
	JIS20K (16K)	264	117.5			25.8
	JIS30K	274	122.5			32.4
	ANSI150	274	122.5			27.1
	JPI150					27.2
	ANSI300	294	132.5			36.6
150 (6")	JIS10K	322	132.5	140.3	413	44.3
	JIS20K (16K)	342	142.5			53.4
	JIS30K	352	147.5			67.0
	ANSI150	340	141.5			47.1
	JPI150					47.2
	ANSI300	359	151			66.2
JPI300			66.6			
200 (8")	—	350	—	199.9	428	39.4
250 (10")	—	450	—	248.8	450	69.4
300 (12")	—	500	—	297.9	472	89.4

EX DELTA OUTLINE DIMENSIONS [SEPARATE TYPE] (Unit in mm)

Wafer Type

- Nominal Sizes 10, 15, 25mm

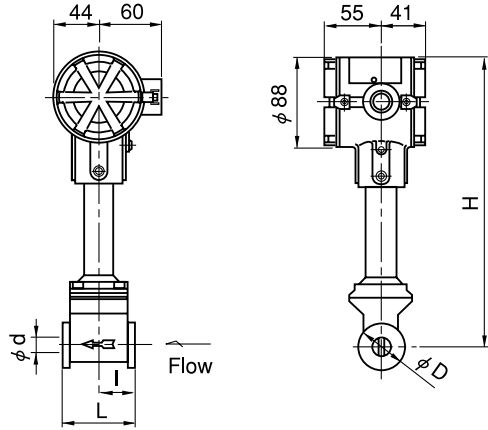

- Nominal Sizes 40~150mm

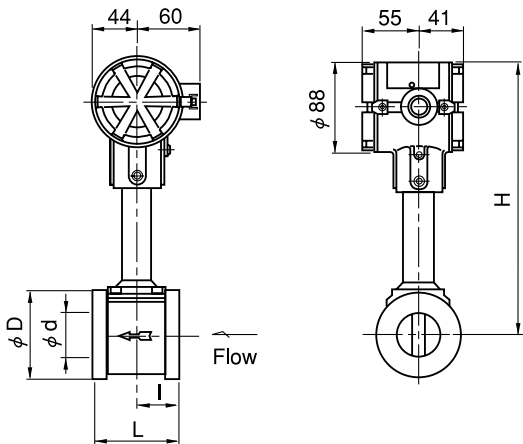

Nominal Size mm (inch)	L	I	φd (Meter I.D.)	φD	H	Approx. Mass (kg)
10 (3/8")	65	32.5	10	40	277	2.4
15 (1/2")	65	32.5	14.5	40	277	2.4
25 (1")	65	32.5	26.6	67	277	3.0
40 (1 1/2")	80	40	37.6	81	262	3.7
50 (2")	80	40	48.5	91	266	3.8
80 (3")	100	40	72.4	126	282	6.6
100 (4")	125	48	95.2	156.2	302	10.3
150 (6")	165	54	140.3	214.9	332	20.2

Flanged Type

- Fixed Sensor Type

- Nominal Sizes 50~150mm

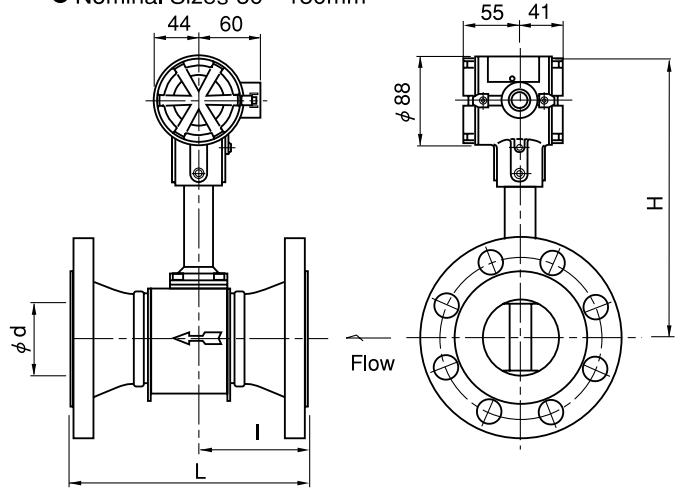

- Nominal Sizes 200~300mm

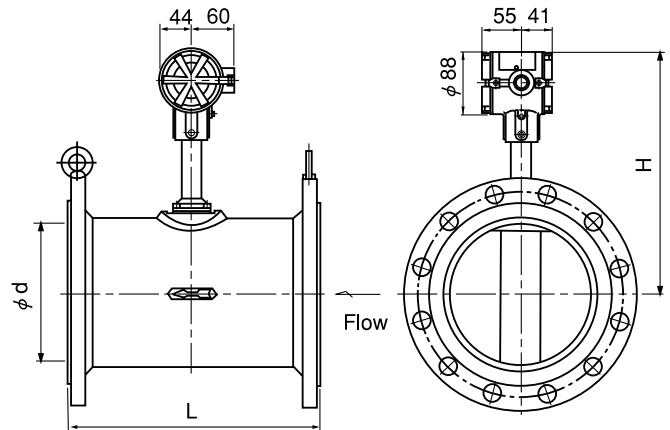

Nominal Size mm (inch)	Flange Rating	L	I	φd (Meter I.D.)	H	Approx. Mass (kg)
50 (2")	JIS10K	173	86.5	48.5	266	8.8
	JIS20K (16K)	181	90.5			9.0
	JIS30K	191	95.5			11.1
	ANSI150	204	102			9.7
	JPI150	—	—			9.8
	ANSI300	217	108.5			11.6
80 (3")	JIS10K	219	99.5	72.4	282	15.0
	JIS20K (16K)	233	106.5			17.7
	JIS30K	243	111.5			21.7
	ANSI150	237	108.5			17.8
	JPI150	—	—			—
	ANSI300	255	117.5			22.3
100 (4")	JIS10K	250	110.5	95.2	302	21.0
	JIS20K (16K)	264	117.5			25.0
	JIS30K	274	122.5			31.6
	ANSI150	274	122.5			26.3
	JPI150	—	—			26.4
	ANSI300	294	132.5			35.8
150 (6")	JIS10K	322	132.5	140.3	332	43.5
	JIS20K (16K)	342	142.5			52.6
	JIS30K	352	147.5			66.2
	ANSI150	340	141.5			46.3
	JPI150	—	—			46.4
	ANSI300	359	151			65.4
200 (8")	—	350	—	199.9	347	38.6
250 (10")	—	450	—	248.8	369	68.6
300 (12")	—	500	—	297.9	391	88.6

■ Replaceable Sensor Type

● Nominal Sizes 50~150mm

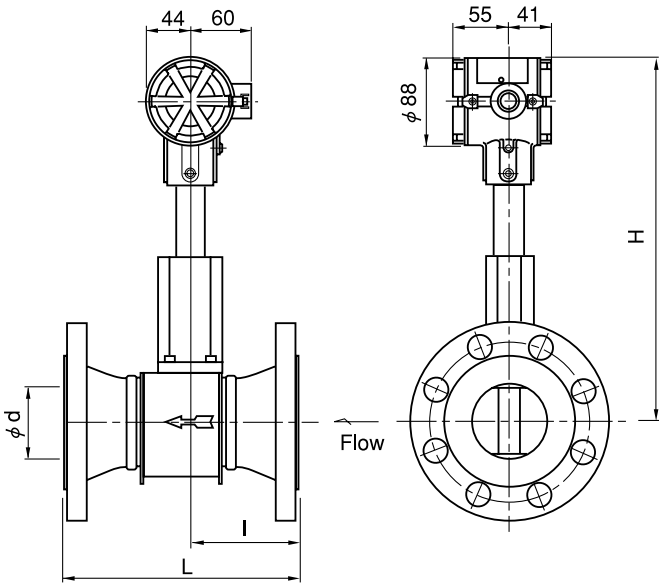

● Nominal Sizes 200~300mm

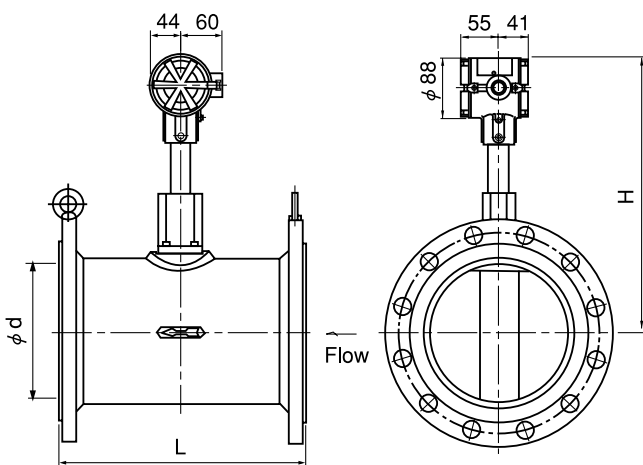

Nominal Size mm (inch)	Frange Rating	L	I	ϕd (Meter I.D.)	H	Approx. Mass (kg)
50 (2")	JIS10K	173	86.5	48.5	347	9.4
	JIS20K (16K)	181	90.5			9.6
	JIS30K	191	95.5			11.7
	ANSI150	204	102			10.3
	JPI150					10.4
	ANSI300	217	108.5			12.2
80 (3")	JIS10K	219	99.5	72.4	363	15.6
	JIS20K (16K)	233	106.5			18.3
	JIS30K	243	111.5			22.3
	ANSI150	237	108.5			18.4
	JPI150					
	ANSI300	255	117.5			22.9
100 (4")	JIS10K	250	110.5	95.2	383	21.6
	JIS20K (16K)	264	117.5			25.6
	JIS30K	274	122.5			32.2
	ANSI150	274	122.5			26.9
	JPI150					27.0
	ANSI300	294	132.5			36.4
150 (6")	JIS10K	322	132.5	140.3	413	44.1
	JIS20K (16K)	342	142.5			53.2
	JIS30K	352	147.5			66.8
	ANSI150	340	141.5			46.9
	JPI150					47.0
	ANSI300	359	151			66.0
200 (8")	—	350	—	199.9	428	39.4
250 (10")	—	450	—	248.8	450	69.4
300 (12")	—	500	—	297.9	472	89.4

SEPARATE TYPE CONVERTER

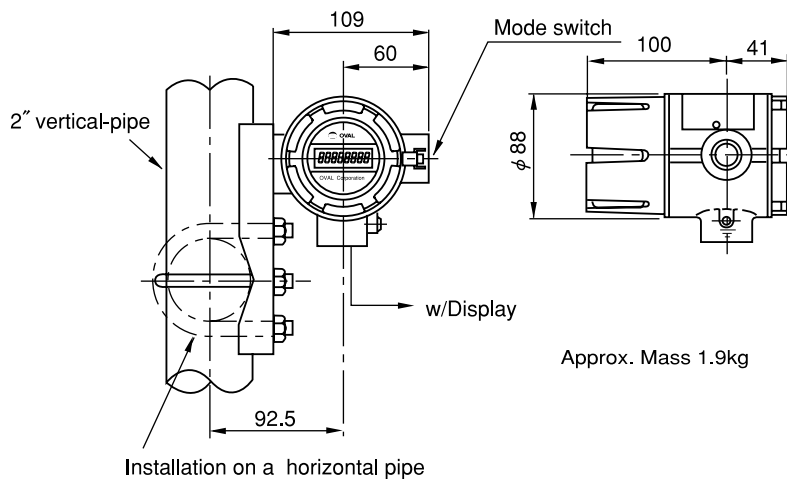

EX DELTA • DIA OUTLINE DIMENSIONS (Unit in mm)

[INTEGRAL PREAMP TYPE]

Wafer Type

- Nominal size 15mm

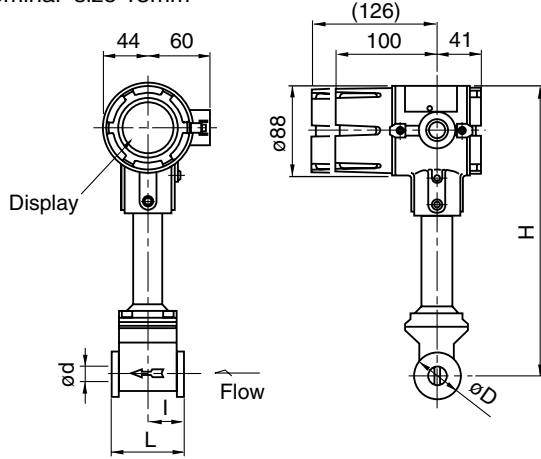

- Nominal size 25mm

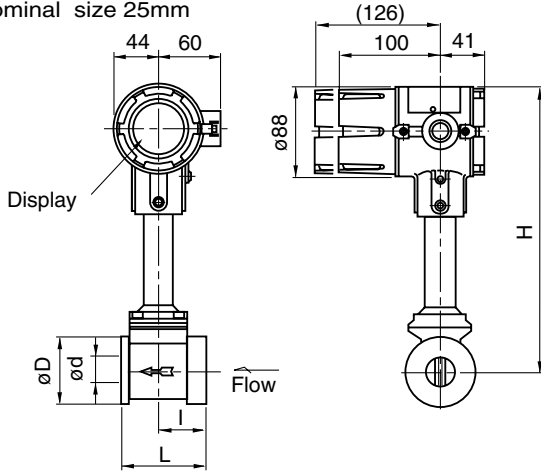

- Nominal sizes 40~80mm

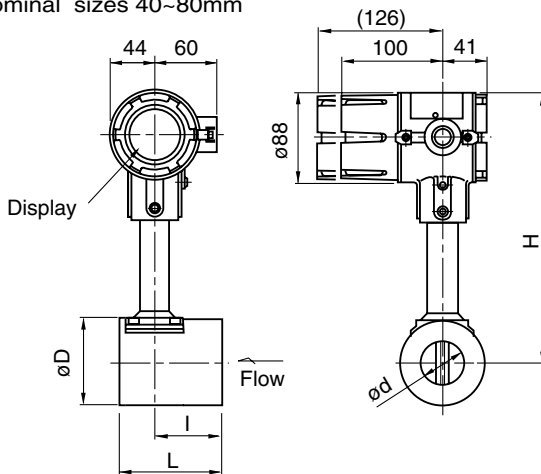

Nominal size (mm)	L	I	ød (Meter i.D.)	øD	H	Approx. Mass (kg)	
						No Display	w/Display
15 (1/2")	65	32.5	14.5	40	277	2.6	2.9
25 (1")	80	47.5	26.6	67	270	3.2	3.5
40 (1 1/2")	100	67	41.2	82	261	3.9	4.2
50 (2")	125	85	52.7	92	266	4.0	4.3
80 (3")	125	85	78.1	127	282	6.8	7.1

Flanged Type

- Fixed Sensor Type

- Nominal sizes 50, 80mm

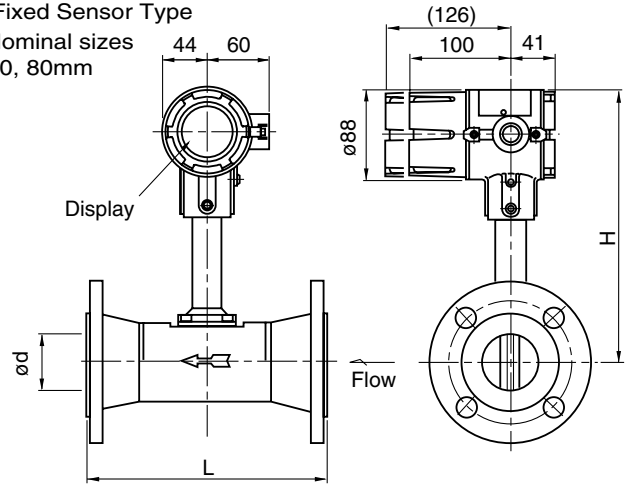

Nominal size (mm)	L	ød (Meter i.D.)	H
50 (2")	229	52.7	266
80 (3")	254	78.1	282

- Replaceable Sensor Type

- Nominal sizes 50, 80mm

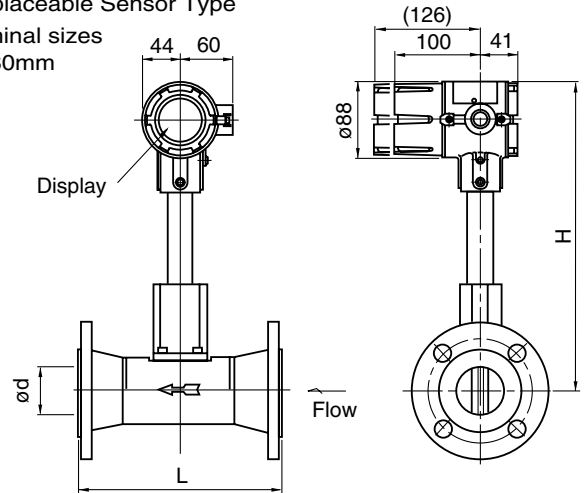

Nominal size (mm)	L	ød (Meter i.D.)	H
50 (2")	229	52.7	34.7
80 (3")	254	78.1	36.3

- Converter PA15 I (w/Indicator), PA15S (w/Totalizer)

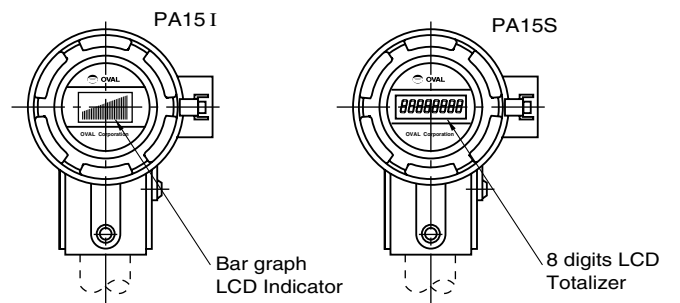

1. Physical orientation of the converter is changeable in 90° steps around the center of mounting bracket.
2. Display orientation is also changeable in 90° steps within the converter.

[SEPARATE-MOUNT PREAMP TYPE]

Wafer Type

- Nominal size 15mm

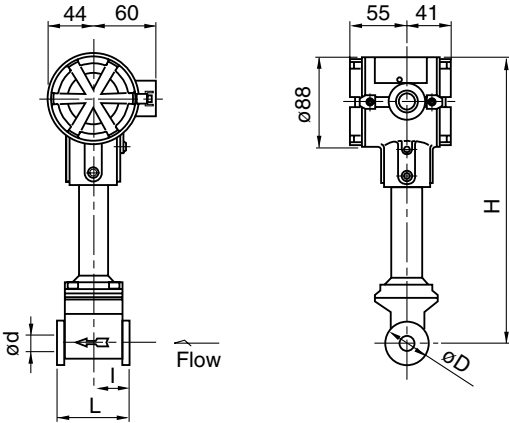

- Nominal size 25mm

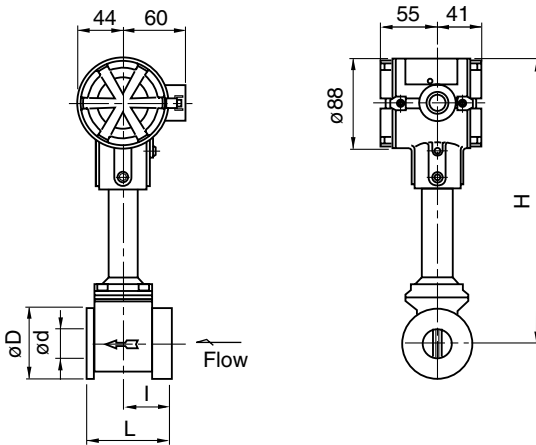

- Nominal sizes 40~80mm

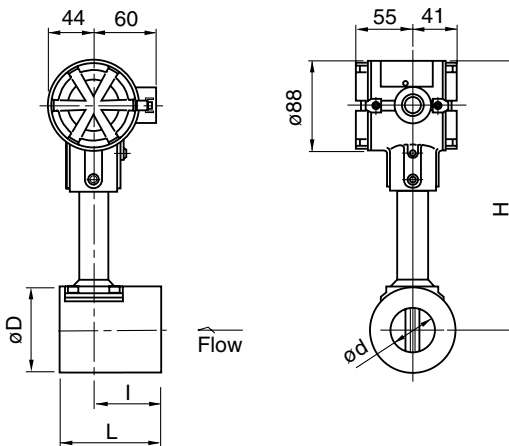

Nominal size (mm)	L	I	ød (Meter i.D.)	øD	H	Approx. Mass (kg)
15 (1/2")	65	32.5	14.5	40	277	2.4
25 (1")	80	47.5	26.6	67	270	3.0
40 (1 1/2")	100	67	41.2	82	261	3.7
50 (2")	125	85	52.7	92	266	3.8
80 (3")	125	85	78.1	127	282	6.6

Flanged Type

- Fixed Sensor Type
- Nominal sizes 50, 80mm

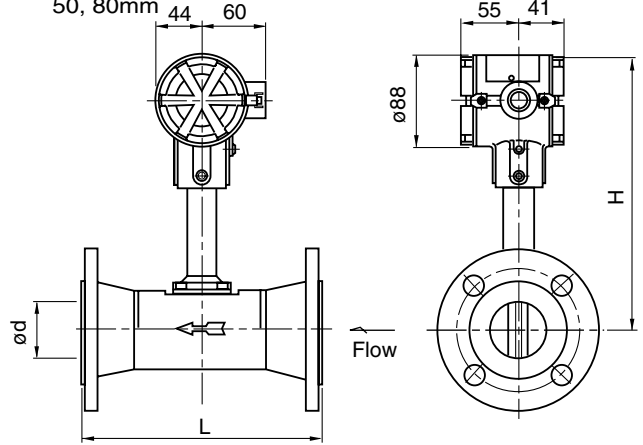

Nominal size (mm)	L	ød (Meter i.D.)	H
50 (2")	229	52.7	266
80 (3")	254	78.1	282

- Replaceable Sensor Type

- Nominal sizes 50, 80mm

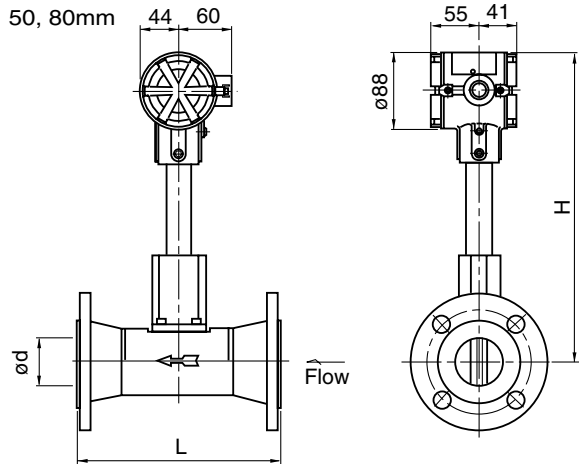

Nominal size (mm)	L	ød (Meter i.D.)	H
50 (2")	229	52.7	347
80 (3")	254	78.1	363

SEPARATE-MOUNT PREAMP

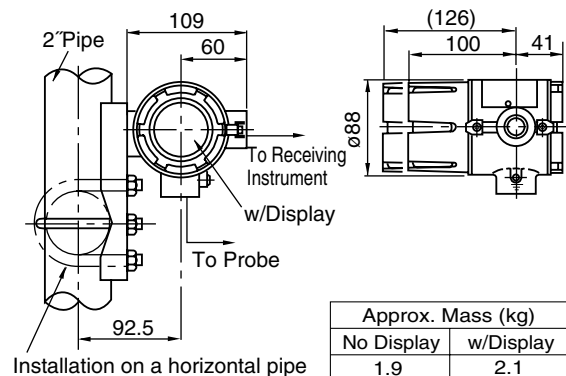

Approx. Mass (kg)	
No Display	w/Display
1.9	2.1

Note: Figures in the brackets show the dimensions for built-in display.

■ INSTALLATION CONDITIONS

1. TYPICAL PIPING INSTRUCTIONS

It is generally required that the flow pattern of a fluid flowing in and out of an inferential type flowmeter be as uniform as possible for accurate metering performance. All account of this, proper flow straightening measures

have to be applied for piping installation of EX DELTA. The standard piping instructions are shown in the following table.

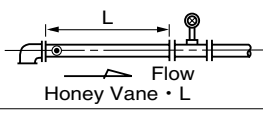
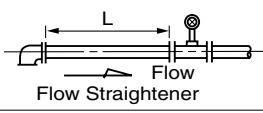
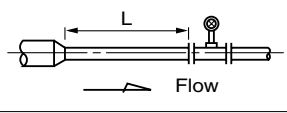
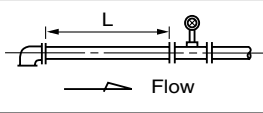
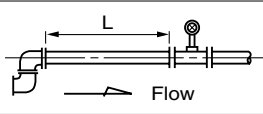
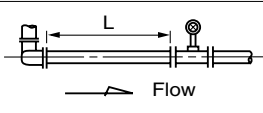
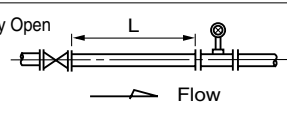
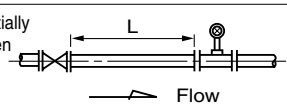
No.	Piping Arrangement	Straight Pipe Length(L)	Remarks
1	 OVAL's Flow-Straightener Honey Vane • L	8D	Refer to Point 4. Applicable to meter size >25mm
	 Flow Straightener	12D	
2	 Flow	15D Min.	A concentric reducer is installed upstream of meter.
3	 Flow	23D Min.	An elbow is installed upstream of meter.
	 Flow	25D Min.	Two elbows are installed upstream of meter.
	 Flow	40D Min.	Two elbows are vertically installed upstream of meter.
4	 Fully Open Flow	15D Min.	A full-open gate valve is installed upstream of meter.
5	 Partially Open Flow	50D Min.	A partially open gate valve, sharp orifice or something that markedly disturbs the flow pattern is upstream of meter.

Note 1: Sch.40 pipe is used for the flow straightener.

2: A short pipe section, 5D or longer, is provided downstream of the meter.

3: Taps for pressure gage and/or thermometer should be located downstream of the meter (Fig. below).

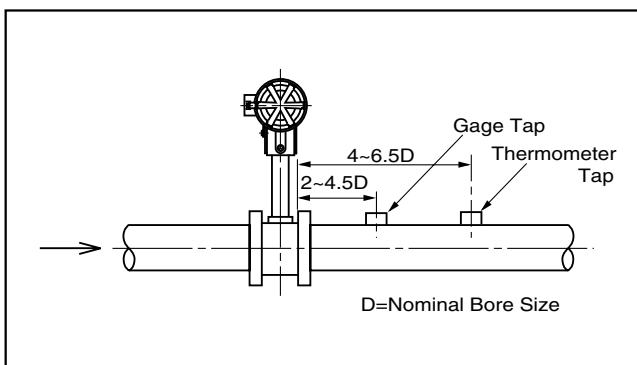

2. LAGGING WORK

If it is desired to thermally insulate the pipeline, simple lagging (without mortar finish) is suggested to facilitate servicing. This arrangement will permit taking off the flowmeter connecting bolts without destroying the lagging.

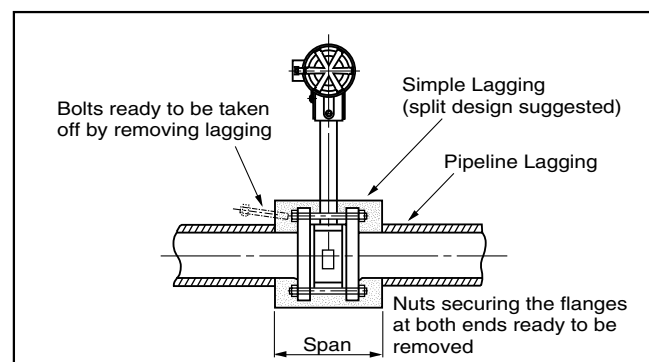

3. ITEMS TO BE NOTED IN PROCESS CONDITIONS

(1)Prevention of Cavitation:

For liquid flow application, line pressure higher than a value calculated from the following equation is applied in order to prevent cavitation.

$$P \geq 2.60\Delta P + 1.25P_o \text{ (MPa [absolute])}$$

where P : Line pressure (MPa)

ΔP : Pressure loss (MPa)

P_o : Vapor pressure of a liquid (MPa [absolute])

(2)Fluctuation:

In case EX DELTA is installed in the line where a blower such as a Roots blower and compressor, or othe device that can generate fluctuated pressure, performance of the flowmeter can be affected by flow fluctuation. Allowable fluctuation pressure is calculated from the following equation.

$$N < \frac{2.25 \rho V^2}{100} \text{ (kPa)}$$

where, N : Fluctuation pressure (kPa)

ρ : Density (kg/m³)

V : Min. velocity (m/s)

4. SPACE SAVING (Reduction of pipe run)

If available space limits the required straight pipe length, a combination Honey Vane S and a short pipe is useful for reducing the total length of upstream pipe.

EX DELTA · SS with a built-in Honey Vane is available with accuracy of $\pm 2\%$ R.D. for liquid service.

Consult the factory for accuracy requirements.

● Honey Vanes

Outline Dimensions

Nom.size (mm)	$\phi D * 1$ (mm)	Honey Vane·S	Honey Vane·L
		t (mm)	L (mm)
25	74	3.5	200
40	89	5.4	320
50	104	6.9	400
80	134	10.2	640
100	159	13.3	800
150	220	19.6	1200
200	270	26	1600
250	333	32.3	2000
300	378	38.7	2400

*1. JIS10K

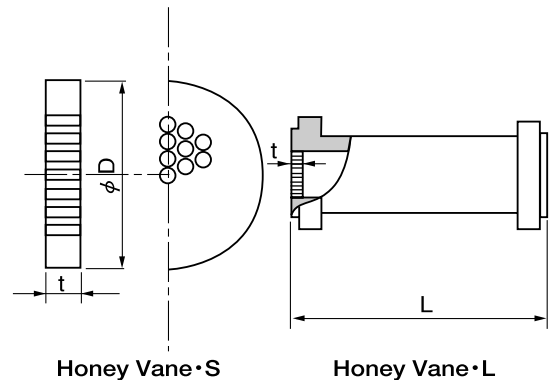

© Flange face to face span of EX DELTA · SS is the same as that of standard EX DELTA. (Refer to pages 10 and 11.)

■ EX DELTA PRODUCT CODE EXPLANATION

Item	Product Code															Description			
	1	2	3	4	5	6	7	—	8	9	10	11	—	12	13		14	15	
Model	V	X																EX DELTA	
Body Style	W																	Wafer type (Nom. sizes: 10~150mm)	Fixed sensor type
	F																	Flanged type (Nom. sizes: 50~300mm) RF is Std.	
	R																		Flanged type (Nom. sizes: 50~300mm) RF is Std.
Application	1																	Standard (Delta shaped vortex shedding bluff body)	
	2																	Dirty fluid system (Diamond shaped vortex shedding bluff body)	See Note 1.
Nominal Bore Size	0 1 0																	10mm (Liquids only)	
	0 1 5																	15mm	
	0 2 5																	25mm	
	0 4 0																	40mm	
	0 5 0																	50mm	
	0 8 0																	80mm	
	1 0 0																	100mm	
	1 5 0																	150mm	
	2 0 0																		200mm
	2 5 0																		250mm
3 0 0																		300mm	
Major Parts Material	—																		
	N																	SCS14A(Nominal sizes 10~150mm) SUS316 (Nominal sizes 200~300mm)	
	C																	SUS316+SFVC2A(Nominal sizes 200~300mm)	See Note 2.
Z																		Special (other than above)	
Flange Rating	1																	JIS 10K	
	2																	JIS 16K	
	3																	JIS 20K	
	4																	JIS 30K	
	5																	ANSI 150	See Note 3.
	6																	ANSI 300	See Note 3.
	7																	JPI 150	
	8																	JPI 300	
	9																	Others	
Sensor Construction	1																	Standard	
	2																	Separate sensor probe type	See Note 4.
Fluids to be Metered	G																	Gas, Steam (<300°C)	
	L																	Liquid (<300°C)	
	S																	High temp. application for gas, steam (over 300°C and <420°C)	
	H																	High temp. application for liquid (over 300°C and <420°C)	
Converter Construction	—																		
	1																	Integral type	
2																		Separate type	
Explosionproof Construction	0																	Nonexplosionproof	
	3																	Intrinsic safety	
Display	1																	w/Totalizer & Digital indicator	See Note 5.
Output signal	0																	Non Output (battery powered type)	

Notes 1. Nominal sizes 15~80mm : Applicable to liquid measurement. (EX DELTA-DIA)

2. Body material for meters 200mm~300mm in nominal size is SUS316 pipe + SFVC2A flanges. Meters approved to comply with high pressure gas safety regulations are not applicable, however.

3. Flange serration for ANSI standard : ANME/ANSI B 16.5—1996.

4. Applicable to dirty fluid system (10, 15mm Liquid) & EX Delta-Dia (15~80mm)

5. The following variables are selectable with an external switch for the display:

- (1) Totalizing counter
- (2) Instantaneous flowrate(/h)
- (3) Instantaneous flowrate(/min)
- (4) Resettable counter

■ EX DELTA・DIA PRODUCT CODE EXPLANATION

Item	Product Code															Description				
	1	2	3	4	5	6	7	-	8	9	10	11	-	12	13			14	15	
Model	V	X																EX DELTA		
Body style			W															Wafer type (Nominal sizes: 15~80mm)	Fixed sensor type See Note 3.	
			F															Flanged type (sizes: 50, 80mm) RF is St'd		
			R																Flanged type (sizes: 50, 80mm) RF is St'd	Replaceable sensor type
Application			2															Diamond shaped bluff body		
Nominal size				0	1	5												15mm		
				0	2	5												25mm		
				0	4	0												40mm		
				0	5	0												50mm		
				0	8	0												80mm		
Material																		N	SCS14A (Nominal sizes 15, 25 wafer type)	
																		C	SUS316	
																		Z	Special (other than above)	
Flange rating																		1	JIS 10K	
																		2	JIS 16K	
																		3	JIS 20K	
																		4	JIS 30K	
																		5	ANSI 150	See Note 2.
																		6	ANSI 300	See Note 2.
																		7	JPI 150	
																		8	JPI 300	
																		9	Other	
Sensor construction																	2		Separate sensor type	
Applicable fluid																		L		Liquid
																		H		High temp. application for liquid (Over 300°C and <420°C)
Converter construction																			1	Integral type
																			2	Separate type
Explosionproof construction																			0	None (non-explosionproof)
																			1	Flameproof in case of a totalizing counter for the model with a totalizing counter, combination of intrinsically safety is applied. See Note 1.
Output signal and display																			0 1	Pulse type
																			1 1	Pulse type (w/Totalizer)
																			0 2	Analog type
																			2 2	Analog type (w/Indicator)

Notes 1. Be sure to use pressure-tight packing in explosionproof application.

2. Flange serration for ANSI standard : ASME/ANSI 1316.5-1996.

3. Applicable item.

Nominal size (mm)	15	25	40	50	80
Wafer type	O	O	O	O	O
Flanged type	-	-	-	O	O

O : Standard - : Option

■ When making inquiries, please specify the following:

Fill in the blanks or check with mark.

Item	Description
1. Fluid to be Metered	
2. Flow Range	Max. _____ Normal _____ Min. _____ <input type="checkbox"/> m ³ /h[normal] <input type="checkbox"/> m ³ /h[actual] <input type="checkbox"/> kg/h
3. Temp. Range	Max. _____ Normal _____ Min _____ °C
4. Press. Range	Max. _____ Normal _____ Min. _____ <input type="checkbox"/> MPa[gauge]
5. Density or Sp. Gr.	Density _____ <input type="checkbox"/> kg/m ³ [normal], <input type="checkbox"/> kg/m ³ [actual] Sp. Gr. _____
6. Viscosity	_____ <input type="checkbox"/> mPa·s, <input type="checkbox"/> mm ² /s at _____ °C
7. Connections	Nom. Size _____ <input type="checkbox"/> mm, <input type="checkbox"/> ", Flange rating <input type="checkbox"/> JIS _____ KRF <input type="checkbox"/> ANSI/JRI _____ RF
8. Flow Straightening Pipe	<input type="checkbox"/> Req'd (Flow straightener and downstream pipe) <input type="checkbox"/> Not req's (Prepare a straight pipe of specified length, I.D., Sch. No.)
9. Compensation	<input type="checkbox"/> Temp./Press. comp. <input type="checkbox"/> Pressure comp. <input type="checkbox"/> Temp. comp.
10. Compensation Range	Temp. _____ ~ _____ °C, Pressure _____ ~ _____ <input type="checkbox"/> MPa [gauge]
11. Compensation Ref.	Ref. temp. _____ °C Press. ref. _____ <input type="checkbox"/> MPa [gauge]
12. Compensation Coeff. (gas measurement)	Z (service conditions) = _____ Zo (standard conditions) = _____
13. Accuracy Test	<input type="checkbox"/> Req'd <input type="checkbox"/> Not req'd
14. Converter	Type : <input type="checkbox"/> Integral construction <input type="checkbox"/> Separate construction Explosionproof construction : <input type="checkbox"/> Non-explosionproof <input type="checkbox"/> Intrinsic safety
15. Miscellaneous	

The specification as of May, 2002 is stated in this GS Sheet. Specifications and design are subject to change without notice.

Sales Representative: